

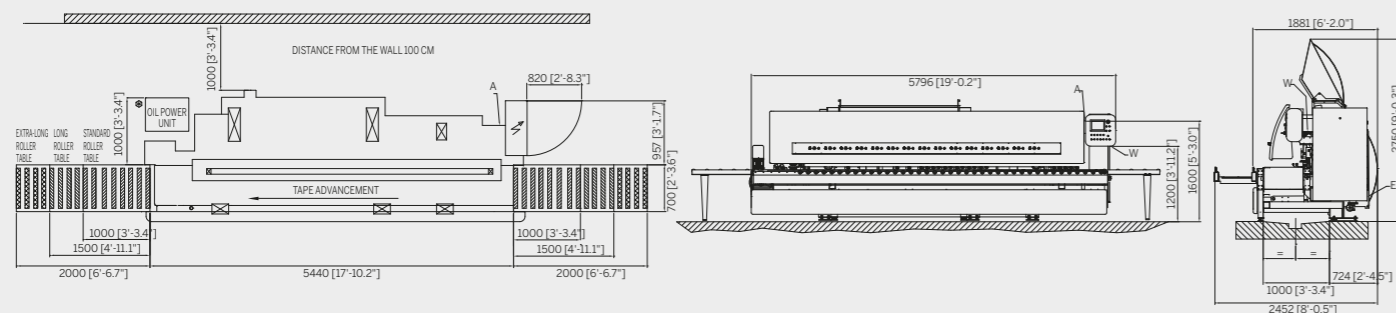

## Technical specification

Technical data and pictures are not binding. Sasso reserves the right to make changes without notice. Speed and modality of cutting can vary according to the thickness and the type of material.



### TECHNICAL DATA

Workable thickness min/max	inches	0,39 - 3,94	mm	10 - 100
Radius max	inches	1,97	mm	50
Min. width	inches	6,3	mm	160
Conveyor belt speed	feet/min	0,33 - 8,2	m/min	0,1 - 2,5
Total install. power	kW	27-31	kW	27 - 31
Approximate weight	lb	8.157,09	kg	3.700
Overall dimension	feet	16,08x5,9x5,9	m	4,9 x 1,8 x 1,8
Water consumption	gal/min	39,62	lt/min	150
Air consumption	Nlt/min	50	Nlt/min	50



## Fast and powerful on any profile

The round and flat edge polishers range has many different models, they change in dimensions and units, but the user-friendliness, technology and reliability reflect Sasso excellence. Speed, profile perfection and hot-galvanization get together with design and technology, to create a range of automatic round and flat edge polishers with multi spindles that ensure high productivity and high quality. Optimal disposition of the spindles for a bullnose machine that accelerates profiling and polishing. This means reducing down time and giving a big hand to the productivity process.



### 1 Versatile

These machines are able to process different kind of edges, round or flat, to shape and polish even large and thick pieces.

### 2 Programmable

Sasso round and flat polishers are all programmable through the control panel placed in front of the machine. Everything is easier in order to get the best result.

### 3 Fast

High productivity for high quality standards, this is the motto of Sasso's round and flat polishers. Using standard tools, they are able to reach excellent processing time, thanks to specific devices.

### 4 High Quality

Every component is made with high quality materials, in order to ensure low and easy maintenance. Hot-galvanized benches make Sasso machines long-lasting.